

CALL FOR CHALLENGERS

Benchmark Problem of Motion Control of Four in-Wheel Motor Actuated Vehicles

This competition is organized for students and younger researchers as a part of conference program of IEEE CDC 2023. An interactive session will be organized for challengers to present their results through poster. ~~The challengers should submit full paper before a delayed deadline.~~

A special issue in the journal "Unmanned Systems" will be organized.

The winners will be awarded at the banquet. For detailed problem formulation, please see the homepage <https://cdc2023.ieeecss.org/benchmark-challenge/>. For downloading the simulator, challengers must previously register by sending the challengers information to fuguoxu@ieee.org.



Benchmark Problem IEEE CDC 2023

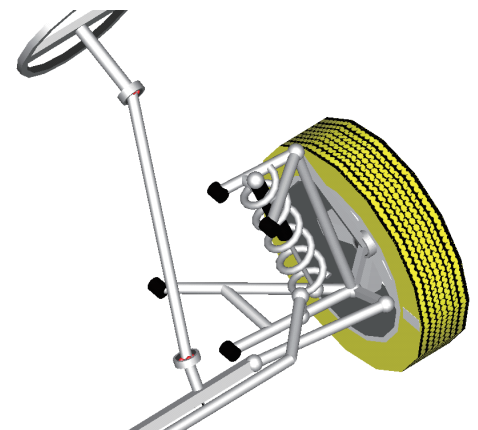
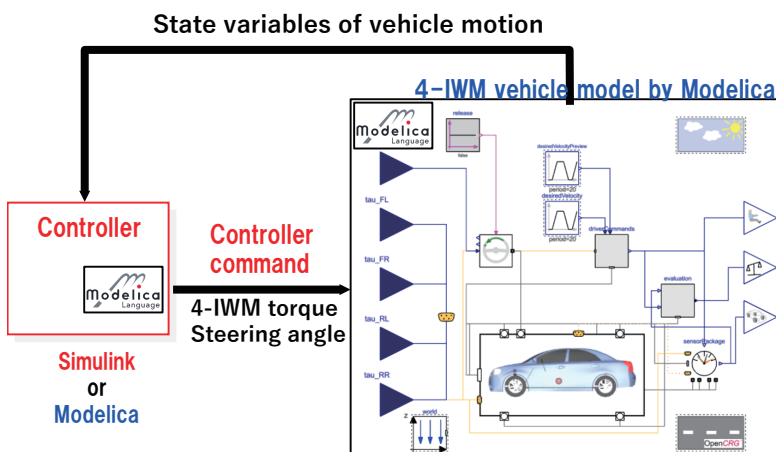

Important dates:

Problem announcement:

April 1st, 2023

~~Full-conference paper submission:-~~

~~–September 20th, 2023~~

One-page poster submission:

November 30th, 2023

The detailed submission information of special issue for benchmark problem will be announced later.

Contact Person: Dr. Fuguoxu Xu, fuguoxu@ieee.org

